

IN MICROCELLULAR STRUCTURE

DESCRIPTION OF THE MAIN FEATURES

The shock absorbing element of these buffers consists of an elastic body of polyurethane expanded resin with a microcellular structure of opened and closed cells.

This special structure makes the buffers capable of high performance as far as elasticity and energy absorption is concerned.

A special characteristic of these buffers is the differentiated reaction according to the impact speed: at a higher impact speed, with the same deflection, the reaction force and consequently the kinetic energy absorption capacity of the buffer increases, as shown in fig. 4.

The buffers are designed to allow the axial deflection to reduce the compressed length to 25% of the free length.

This reduction will increase the outside diameter by only 40%.

The "deflection load" curves show that under shock loading causing up to 50% deflection, the buffers reaction will be similar to metal springs. The system offers the optimum in mechanical energy absorption resulting in minimizing the final impact force imposed on the structure.

The material of the elastic element is anti-aging, with a good resistance to mechanical wear, oil, grease and gasoline; its structure is homogeneous and self-extinguishing.

In each buffer a steel chain is encased and attached to the metallic support in order to avoid damage to people or property, in case of detachment because of radial impacts.

The working temperature is limited to a range of -30° to a $+80^{\circ}\text{C}$.

NOTE: The surface contacting to the buffer should be pattedened.

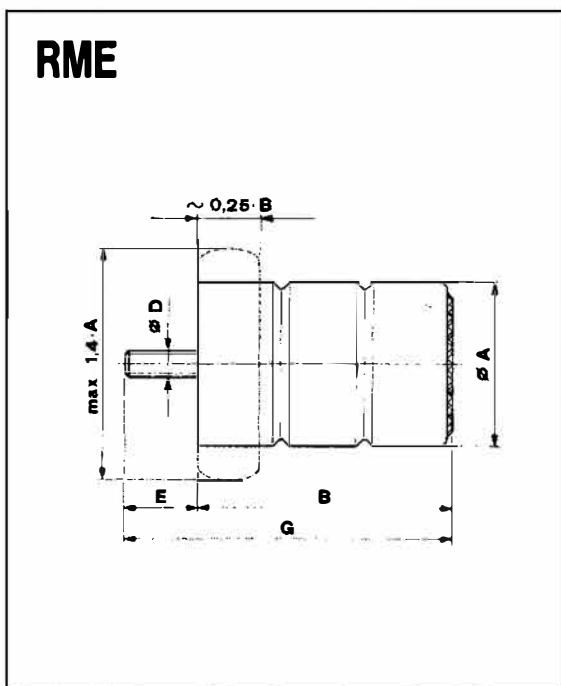

Type	ϕA	B	ϕD	E	G	Weight (kg)
RME.080.080	80	80	M12	35	115	0,350
RME.080.120	80	120	M12	35	155	0,455
RME.100.100	100	100	M12	35	135	0,600
RME.100.150	100	150	M12	35	185	0,800
RME.125.125	125	125	M12	35	160	1,065
RME.125.190	125	190	M12	35	225	1,380
RME.160.160	160	160	M12	40	200	2,620
RME.160.240	160	240	M12	40	280	3,490
RME.200.200	200	200	M12	40	240	4,510
RME.200.300	200	300	M12	40	340	6,160
RME.250.250	250	250	M24	80	330	9,240
RME.250.375	250	375	M24	80	455	12,390
RME.315.315	315	315	M24	80	395	17,190
RME.315.475	315	475	M24	80	555	23,540
RME.400.400	400	400	M30	80	480	34,780
RME.400.600	400	600	M30	80	680	48,580

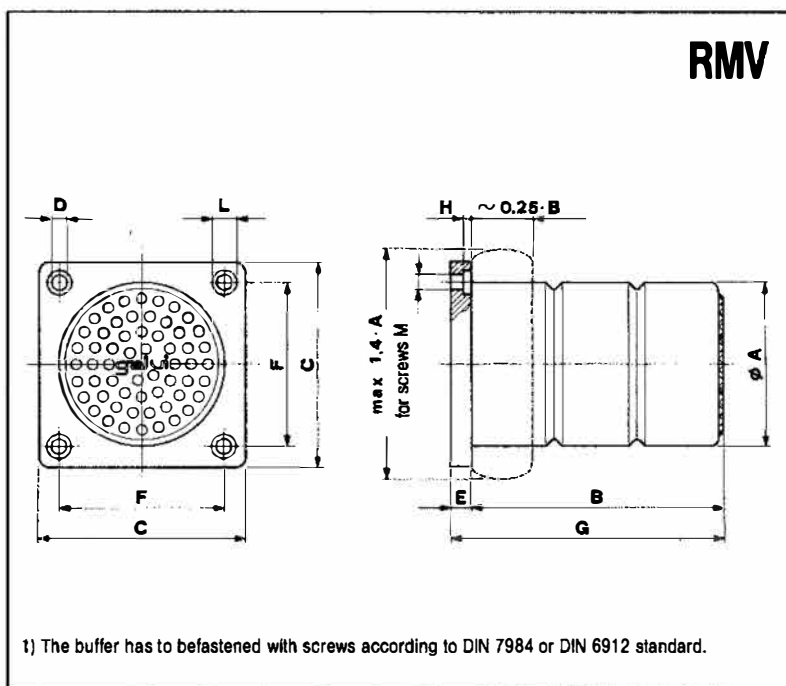

Type	ϕA	B	C	D	E	F	G	H	L	M ⁽¹⁾	Weight (kg)
RMV.063.063	63	63	80	9	8	63	71	—	—	M8	0,230
RMV.063.095	63	95	80	9	8	63	103	—	—	M8	0,275
RMV.080.080	80	80	100	11	10	80	90	—	—	M10	0,440
RMV.080.120	80	120	100	11	10	80	130	—	—	M10	0,545
RMV.100.100	100	100	125	11	10	100	110	—	—	M10	0,750
RMV.100.150	100	150	125	11	10	100	160	—	—	M10	0,950
RMV.125.125	125	125	160	14	12	125	137	5	20	M12	1,535
RMV.125.190	125	190	160	14	12	125	202	5	20	M12	1,850
RMV.160.160	160	160	200	14	12	160	172	5	20	M12	2,950
RMV.160.240	160	240	200	14	12	160	252	5	20	M12	3,820
RMV.200.200	200	200	250	18	15	200	215	6	26	M16	5,600
RMV.200.300	200	300	250	18	15	200	315	6	26	M16	7,250
RMV.250.250	250	250	315	18	15	250	265	6	26	M16	10,000
RMV.250.375	250	375	315	18	15	250	390	6	26	M16	13,150
RMV.315.315	315	315	400	18	15	315	330	6	26	M16	18,200
RMV.315.475	315	475	400	18	15	315	490	6	26	M16	24,550
RMV.400.400	400	400	500	22	20	400	420	7	33	M20	39,000
RMV.400.600	400	600	500	22	20	400	620	7	33	M20	52,280
RMV.500.500	500	500	630	26	20	500	520	8	39	M24	76,300